

Checking and testing

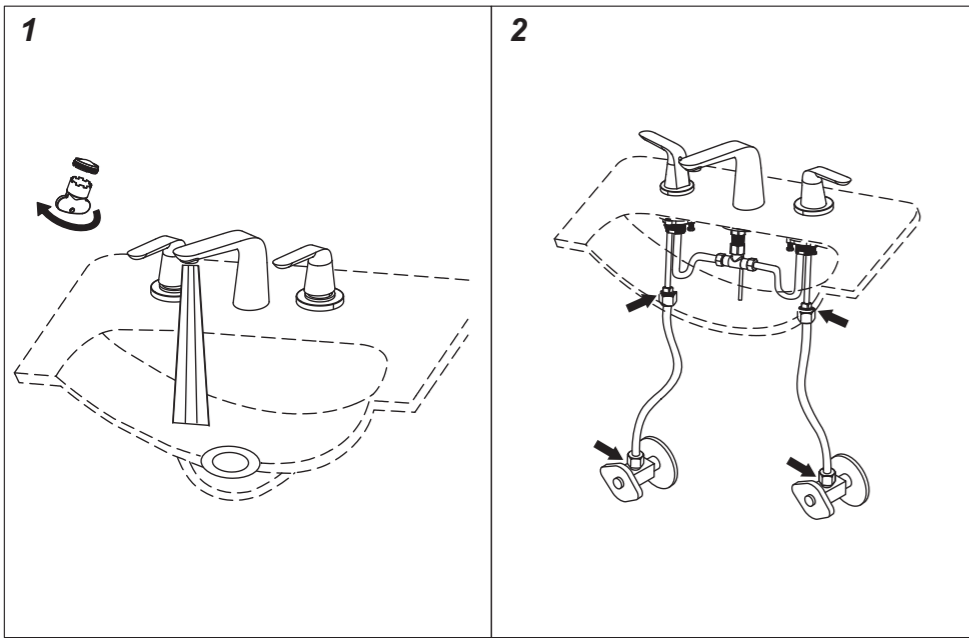

1. Remove the aerator by aerator wrench. Turn the faucet handle all the way on, turn on hot and cold water supply and flush water lines for one minute. Reinstall aerator by aerator wrench.
2. Check all connections at arrows for leaks, re-tighten it if necessary. **BUT DON'T OVERTIGHTEN**

RECOMMENDED TOOLS

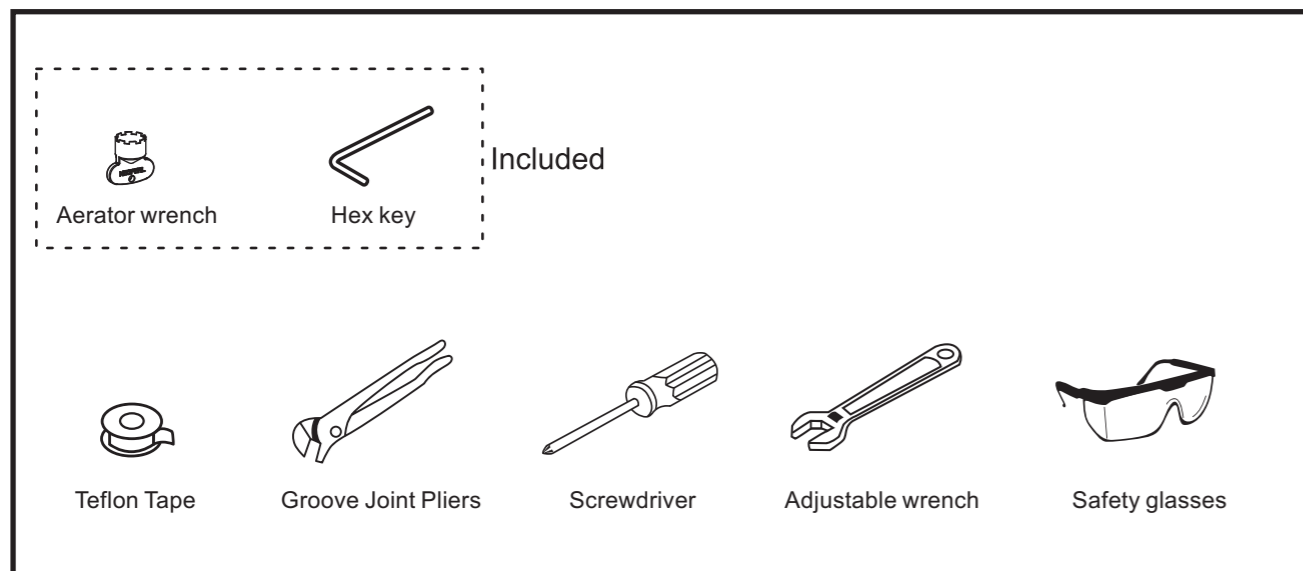

BLOSSOM



MODEL NO.:F01 107

DESCRIPTION:WIDE SPREAD LAVATORY FAUCET

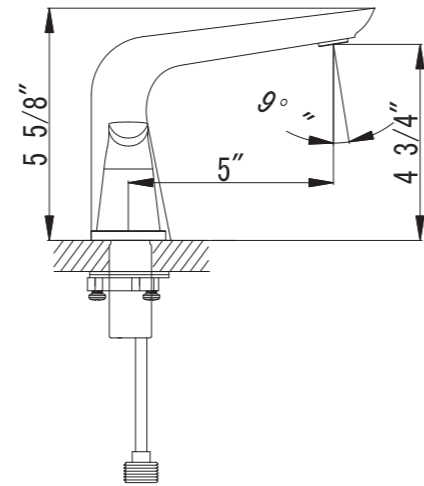
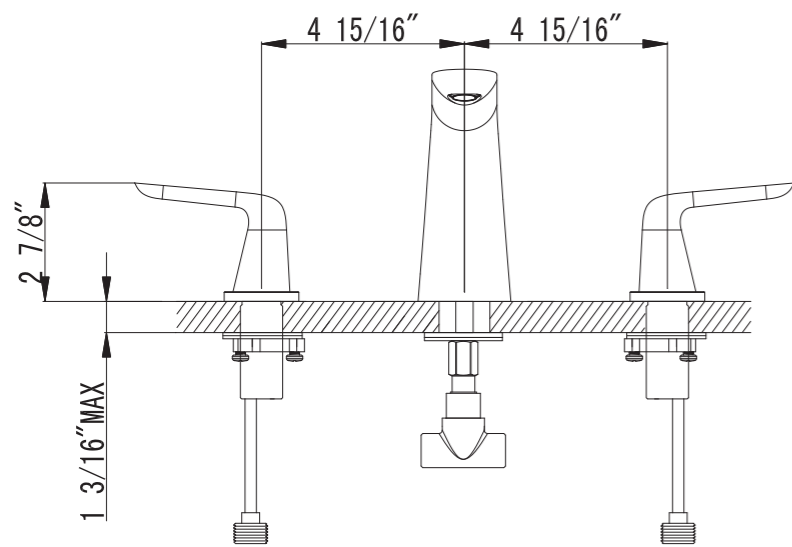

Faucet installation

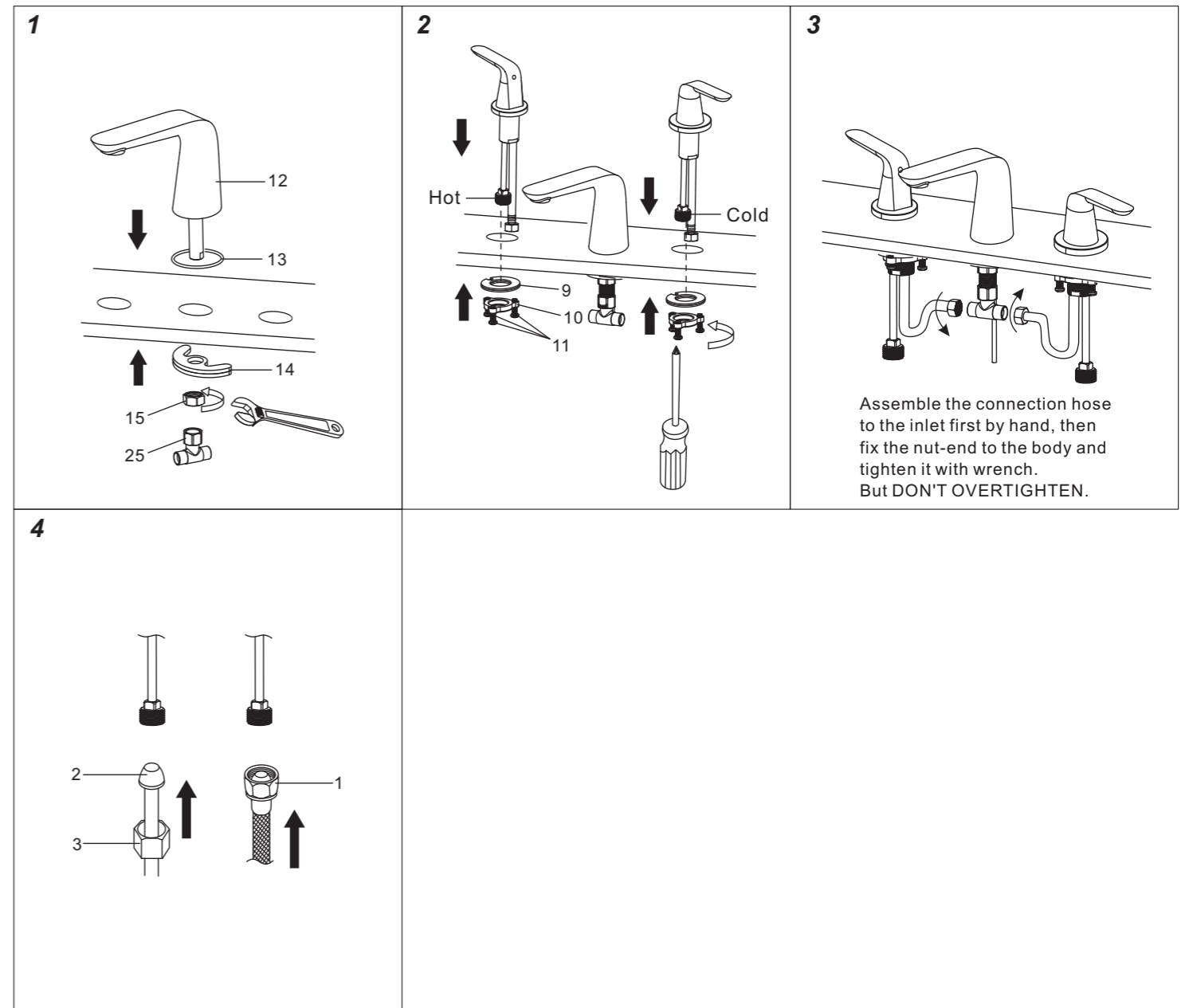

Assemble the connection hose to the inlet first by hand, then fix the nut-end to the body and tighten it with wrench. But **DON'T OVERTIGHTEN**.

Parts list

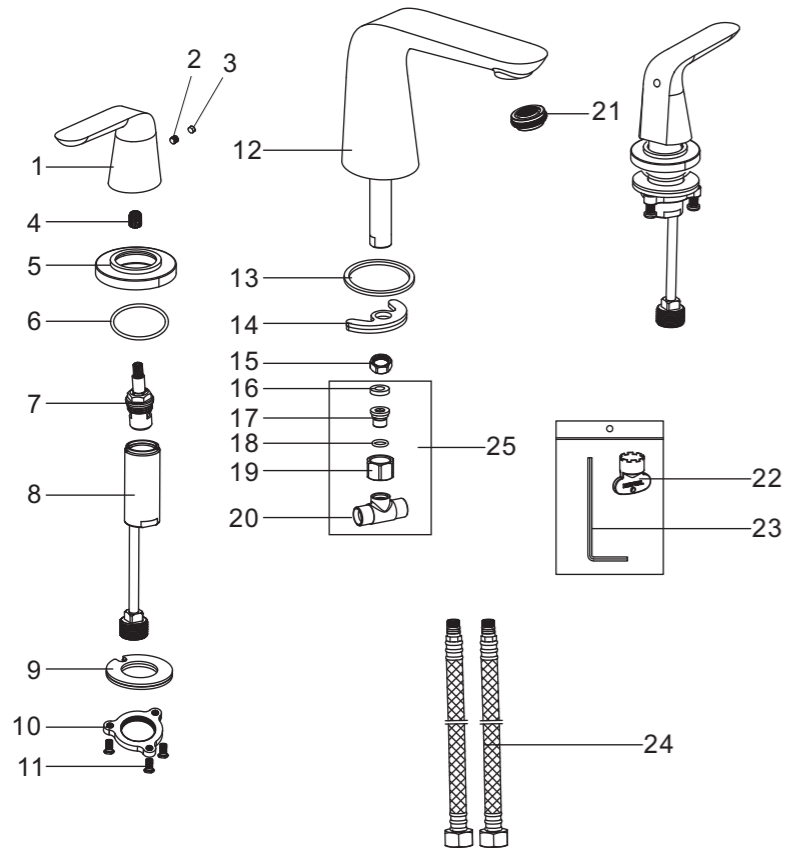

NO.	PART NAME
1	Handle
2	Screw
3	Handle button
4	Adapter
5	Handle flange
6	O-ring
7	Cartridge
8	Inlet pipe
9	Gasket assembly
10	Lock nut
11	Screw
12	Body
13	O-ring
14	Gasket assembly
15	Lock nut
16	Washer
17	Connector
18	O-ring
19	Connector
20	Water valve
21	Aerator
22	Aerator wrench
23	Allen key
24	Flexible hose
25	Connector assembly

- Position the o-ring #13 and body #12 in the installation surface as shown and secure it with gasket assembly #14 and tighten the lock nut #15 with adjustable wrench. Then assemble the connector assembly #25 to the faucet and tighten it with adjustable wrench.
- Position the handle in installation surface as shown and secure it with fixing kit (#9,#11,#11) and tighten the screw #11 with screwdriver. Repeat the above steps for the other handle. **Caution: please be caution with the position of hot and cold handles.**
- Assemble the connection hose to the inlet first by hand, then fix the nut-end to the body and tighten it with wrench. **But DON'T OVERTIGHTEN.**
- Make connections to water lines. Use 1/2" IPS faucet connections #1, or use 3/8" O.D. ball nose risers #2 with coupling nuts #3. Use wrenches to tighten connections. Take care to not overtighten.